

# MAXIM

## MAX7443 Evaluation Kit

### General Description

The MAX7443 evaluation kit (EV kit) evaluates the MAX7443, a low-cost triple-channel video reconstruction filter for composite and S-video applications. The EV kit operates from a single 5V supply. The MAX7443 EV kit can also be used to evaluate the MAX7444, a similar device with a high-frequency boost option.

### Component List

DESIGNATION	QTY	DESCRIPTION
C1	1	1 $\mu$ F $\pm$ 20%, 6.3V X5R ceramic capacitor (0603) Murata GRM188R60J106K TDK C1608X5R0J105K
C2, C6, C7	3	0.1 $\mu$ F $\pm$ 10%, 16V X7R ceramic capacitors (0603) Murata GRM188R71C104K TDK C1608X7R1C104KT
C3, C4, C5	3	220 $\mu$ F $\pm$ 20%, 6.3V aluminum electrolytic capacitors (6.3mm x 6.0mm) SANYO 6EV220AX
JU1, JU2, JU3	3	3-pin headers
JU4, JU5	2	2-pin headers
R1–R5	5	75 $\Omega$ $\pm$ 1% resistors (0603)
R6, R7	2	200 $\Omega$ $\pm$ 1% resistors (0603)
R8, R9	2	162 $\Omega$ $\pm$ 1% resistors (0603)
U1	1	Maxim triple-channel video reconstruction filter and buffer for composite and Y/C outputs MAX7443ESA+ (8-pin SO-EP)
YIN, CIN, YOUT, CVOUT, COUT	5	BNC PCB mount connectors
—	5	Shunts
—	1	PCB: MAX7443 Evaluation Kit+

### Features

- ◆ 5V Single Supply
- ◆ Compatible with Standard Video Test Equipment
- ◆ Surface-Mount Construction
- ◆ Fully Assembled and Tested

### Ordering Information

PART	TYPE
MAX7443EVKIT+	EV Kit

+Denotes lead-free and RoHS-compliant.

**Note:** To evaluate the other device in the family, the MAX7444, request a free MAX7444ESA+ sample with the MAX7443 EV kit.

### Quick Start

#### Recommended equipment

Before beginning, the following equipment is needed:

- Single 5V DC power supply
- Video signal generator (e.g., Tektronix TG 2000)
- Video measurement equipment (e.g., Tektronix VM 700A)

#### Procedure

The MAX7443 EV kit is a fully assembled and tested surface-mount board. Utilize the following steps to verify the board operation. **Caution: Do not turn on the power supply until all connections are completed:**

- 1) Verify that there are shunts installed on JU1 and JU3 (pins 1-2) and JU2 (pins 2-3).
- 2) Verify that there are shunts across jumpers JU4 and JU5.
- 3) Connect the luma output from the video signal generator to the YIN BNC connector on the EV kit.
- 4) Connect the chroma output from the video signal generator to the CIN BNC connector on the EV kit.
- 5) Connect the input of the video measurement equipment to the YOUT, COUT, or CVOUT BNC connectors on the EV kit.

### Component Suppliers

SUPPLIER	PHONE	WEBSITE
Murata Mfg. Co., Ltd.	770-436-1300	www.murata.com
SANYO NA Corp.	619-661-6322	www.sanyo.com
TDK Corp.	847-803-6100	www.component.tdk.com

**Note:** Indicate that you are using the MAX7443/MAX7444 when contacting these component suppliers.

# MAX7443 Evaluation Kit

- 6) Connect the 5V supply to the PCB pad labeled VCC. Connect the pad labeled GND to the ground of the power supply.
- 7) Set the signal generator for the desired video signal, such as multiburst.
- 8) Turn on the 5V DC power supply.
- 9) Analyze any of the output signals with the VM700A video measurement.

## Detailed Description

### Jumper Selection

The MAX7443 EV kit provides options for evaluation with a video signal generator output or a current output video DAC (encoder). Table 1 lists the jumper settings

for selecting the input from either a video generator or a DAC (encoder). When interfacing to a video DAC or encoder output, the 200Ω termination resistor is provided on the board and selected by changing jumpers JU1 and JU3. A typical DAC termination resistor is 200Ω. If the full-scale DAC output current is different than ≈5mA, change the 200Ω resistor accordingly to get 1V at the input of the MAX7443.

The MAX7443 EV kit incorporates jumper JU2 to control the gain setting. Table 2 lists the JU2 functions.

### Evaluating MAX7444

The MAX7443 EV kit can be also used to evaluate the MAX7444. To evaluate the MAX7444, replace the MAX7443ESA+ with a MAX7444ESA+.

**Table 1. Jumpers JU1, JU3, JU4, and JU5 Functions**

JU1 SHUNT POSITION	JU3 SHUNT POSITION	INPUT TERMINATION (Ω)
1-2*	1-2*	75
2-3	2-3	200
All other combinations		Undefined

\*Default position.

**Note:** To emulate a 200Ω DAC source resistor when driving from a 75Ω generator, remove jumpers JU4 and JU5. The 162Ω resistor added to the standard 75Ω termination equals approximately 200Ω.

**Table 2. JU2 Functions**

JU2 SHUNT POSITION	GSET PIN	GAIN (dB)
1-2	Connected to VCC	9.5
2-3	Connected to GND	6
Not installed	Not connected	12

# MAX7443 Evaluation Kit

Evaluates: MAX7443/MAX7444

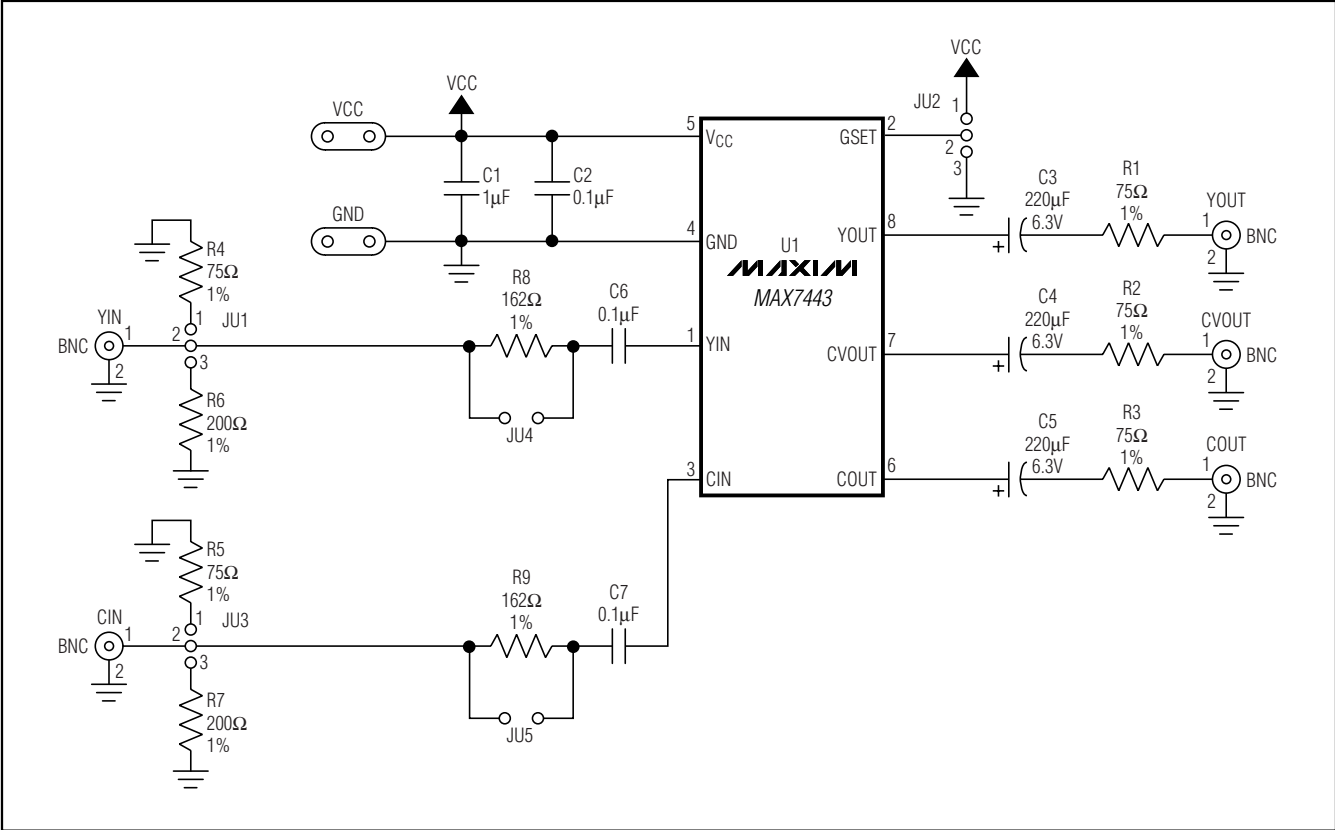

Figure 1. MAX7443 EV Kit Schematic

# MAX7443 Evaluation Kit

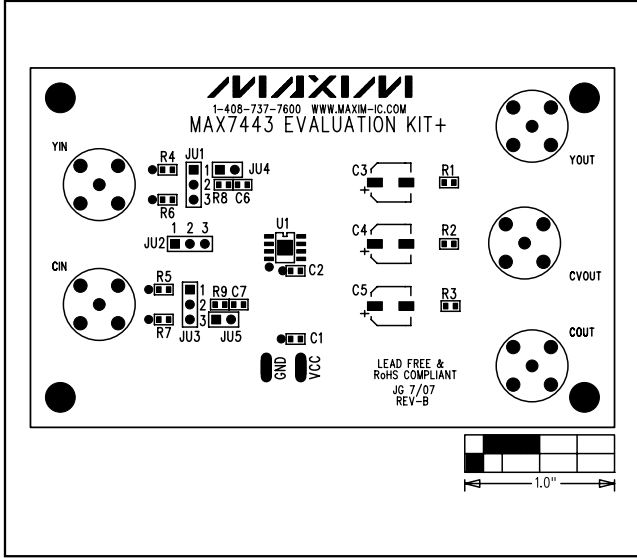

Figure 2. MAX7443 EV Kit Component Placement Guide—Top Silkscreen

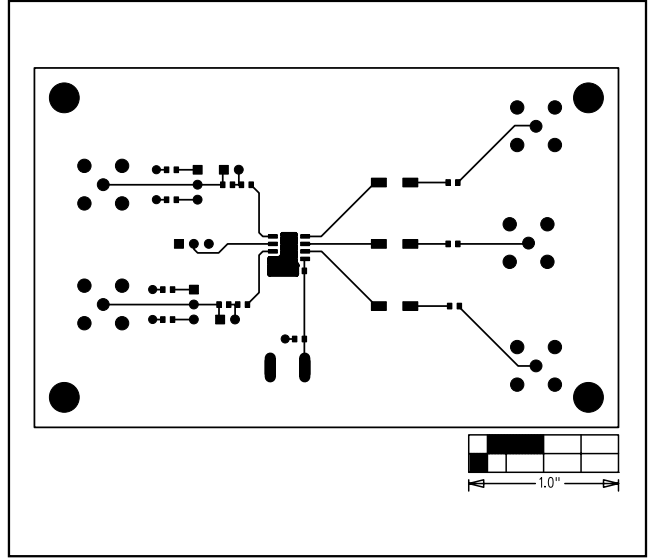

Figure 3. MAX7443 EV Kit PCB Layout—Component Side

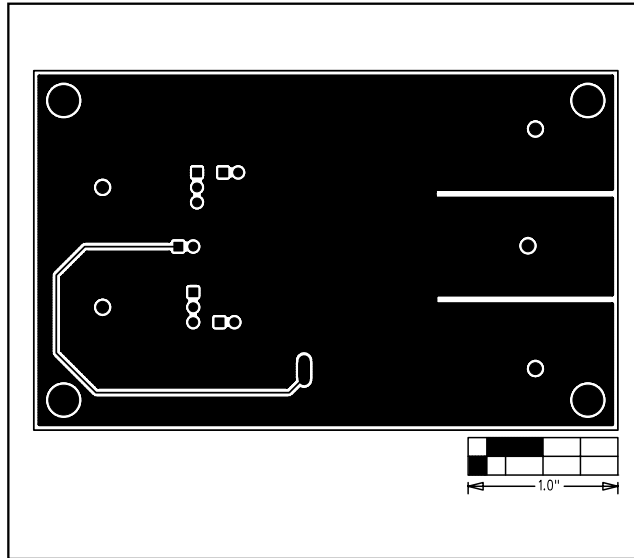

Figure 4. MAX7443 EV Kit PCB Layout—Solder Side

## Revision History

Pages changed at Rev 1: 1–4

Maxim cannot assume responsibility for use of any circuitry other than circuitry entirely embodied in a Maxim product. No circuit patent licenses are implied. Maxim reserves the right to change the circuitry and specifications without notice at any time.

4 \_\_\_\_\_ **Maxim Integrated Products, 120 San Gabriel Drive, Sunnyvale, CA 94086 408-737-7600**

© 2007 Maxim Integrated Products

**MAXIM** is a registered trademark of Maxim Integrated Products, Inc.